

Quick connection guide

getting ready to work

Plaster unit with gun AK-10 PRO

OPTION 1

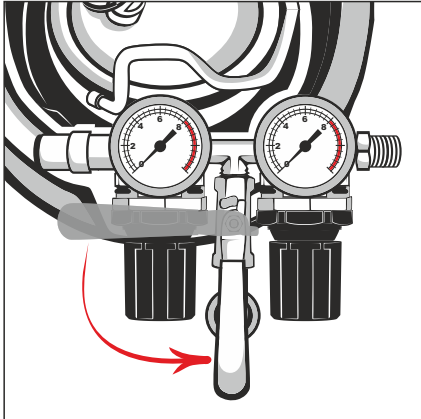

1. Screw the reductor into and open the ball valve on the reductor.

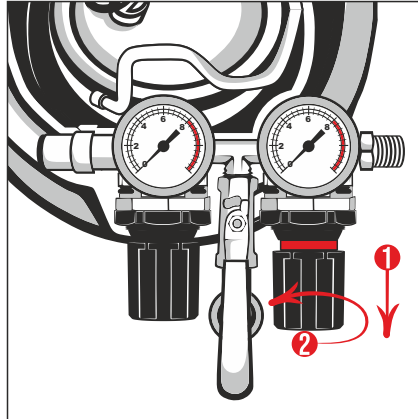

2. Using your hand pull the knob handle of the reductor and turn it left until you will feel resistance. Repeat this action with the second knob handle (manometers are often fabrically unscrewed).

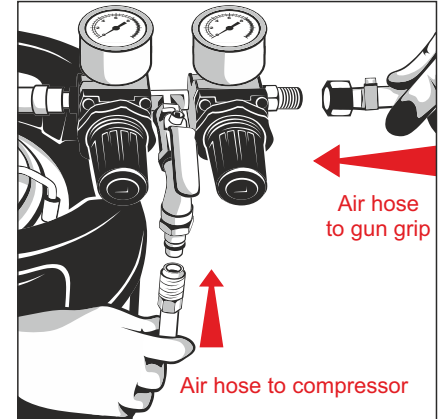

3. Connect air supply hose to compressor and air supply hose to gun grip.

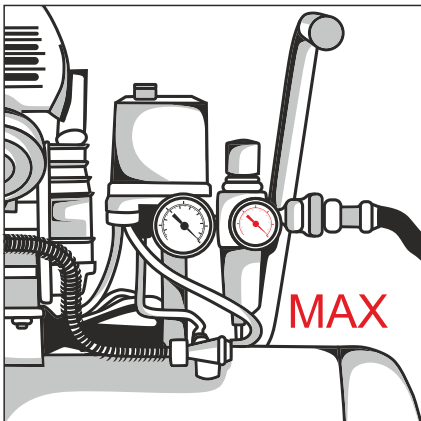

4. Set maximum pressure on the compressor. Compressor should have at least 2 pistons in V mode and capacity 50 L.

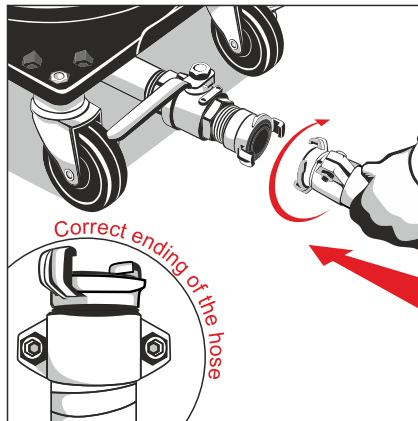

5. Attach to the bottom exhaust hose 25 mm ended with GEKA claw coupling **with a strong clamp bracket**.

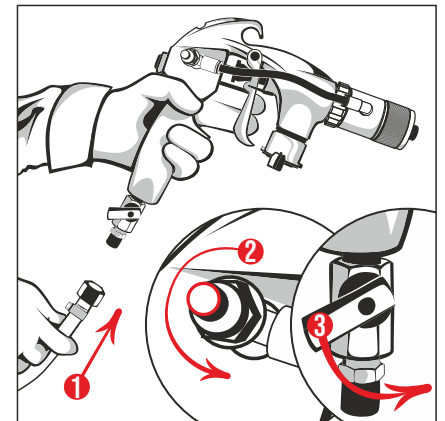

6. Connect air hose to the plaster gun. Make sure that elbow valve which is placed on the side of gun's body is fully unscrewed. Next, open the small ball valve of the plaster gun.

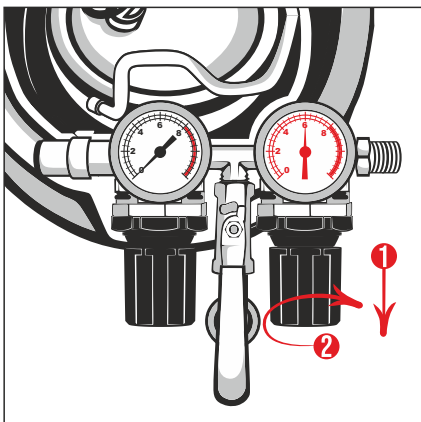

7. Turn right knob handle to the right. Set pressure for 6 BAR.

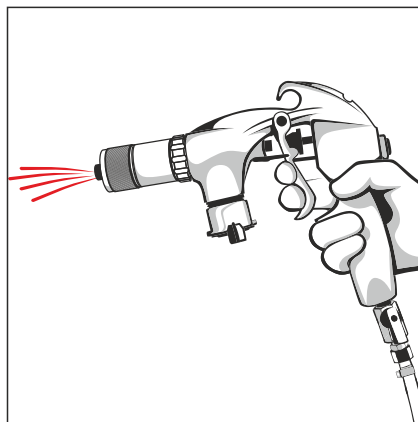

8. By pressing the trigger of the gun check if air flows correctly (pressure of air shouldn't fall below 4 BAR on right reductor of manometer). If air supply is disrupted check needle patency and check leakproofness of gun as shown in step no 9. If air supply flows correctly skip step 9.

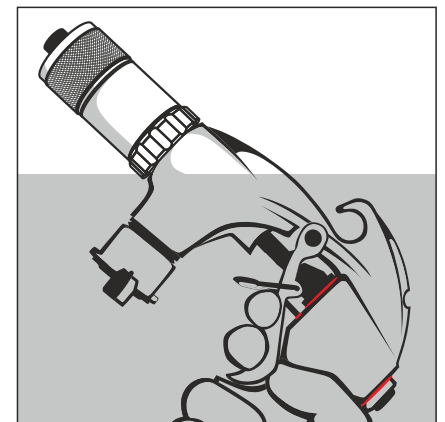

9. Check leakproofness of gun by drowning it in water so it's nozzle is above water level and pull the trigger. On the picture are marked places where leaks may probably appear. If air supply flows correctly skip this step.

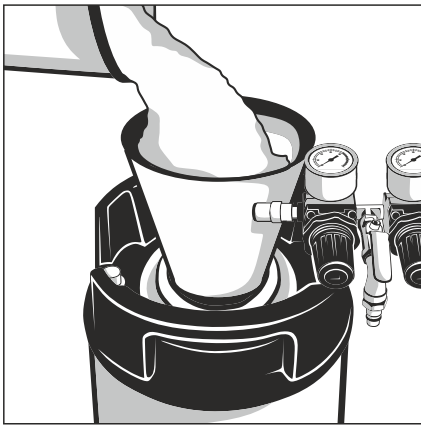

10. Open the tank, pour in material and close the tank. Material should be diluted as recommended by material producer.

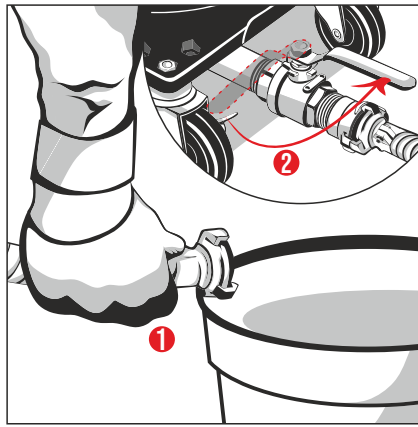

11. Put material hose above bucket or different container and open ball valve near the bottom exhaust of the tank.

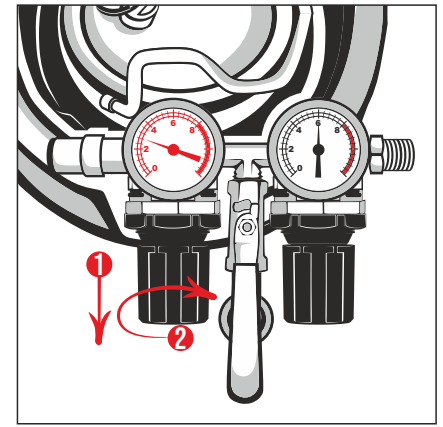

12. Increase pressure in the tank until material will flow freely.



13. Material should flow through the hose.

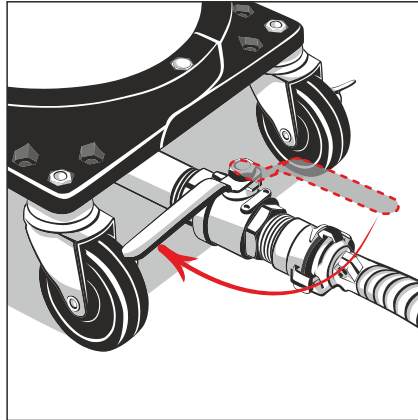

14. Close the material valve.

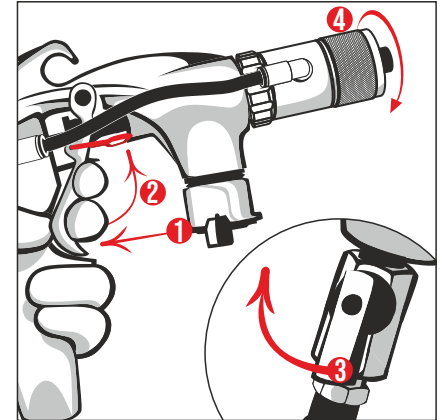

15. Press and block the trigger. Screw small ball valve on the gun then unscrew nozzle nut and remove nozzle from the gun.

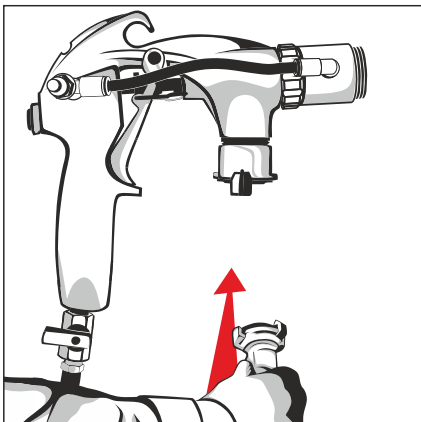

16. Attach material hose to the gun.

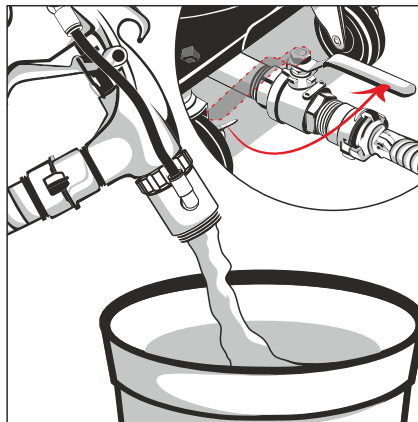

17. Open ball valve near bottom exhaust for 5 seconds and close it. Material should flow through the gun.

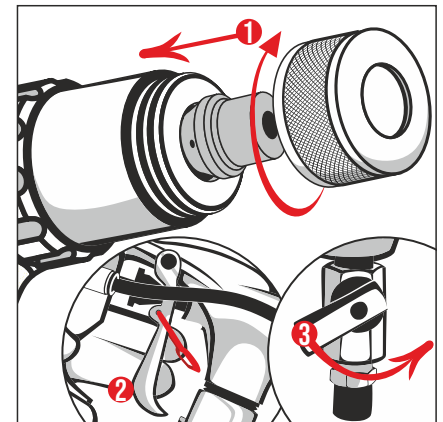

18. Put on proper nozzle to the gun and screw the nut. Release the hold of gun's trigger. **Then open small ball valve on the gun.**

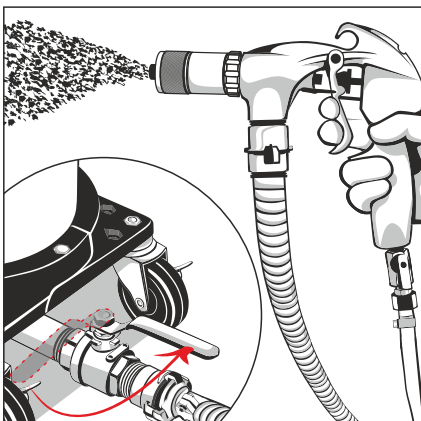

19. Open ball valve on the bottom exhaust of the tank. You can start working!

ATTENTION! If you are using hoses longer than 5 metres or you are working on heights increase the pressure on the tank so that you will balance higher resistance of material in the hose.

For plaster and gypsum substances use dilution as recommended by material producer.

Always first cut supply of material then supply of air!

NEVER close the small ball valve on the gun grip while working.

To make cleaning of the tank and flow of the material to bottom exhaust easier spray it's inside with WD-40 product or silicone spray. Before you start working you should rinse inside of material hose with water.

CHANGING GUN TO OPTION 2

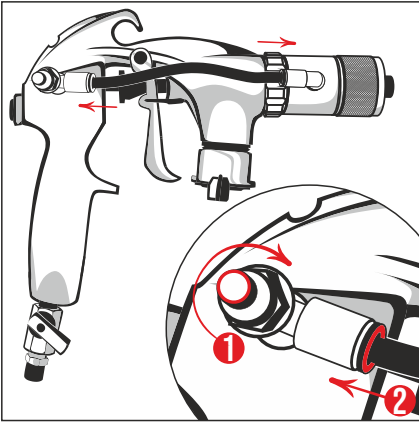

1. Screw elbow valve which is placed on the side of gun's body. Next remove black hose by pressing flange at the elbow valve and screwed elbow.

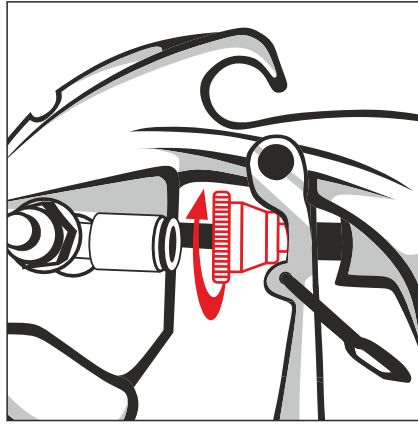

2. Unscrew needle from needle's cap.

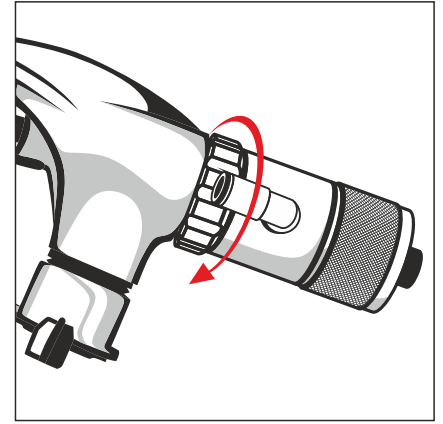

3. Unscrew nozzle's cap.

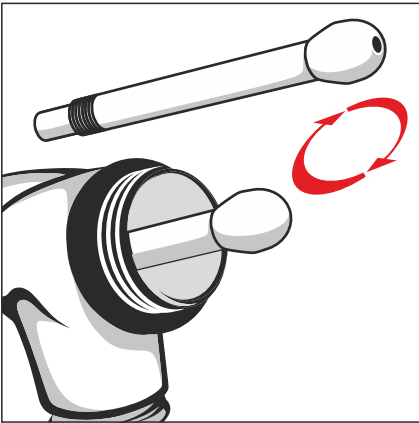

4. Change needle without hole for the one attached to the kit.

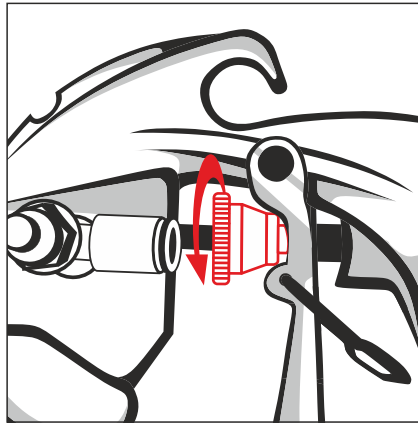

5. Screw needle to the needle's cap.

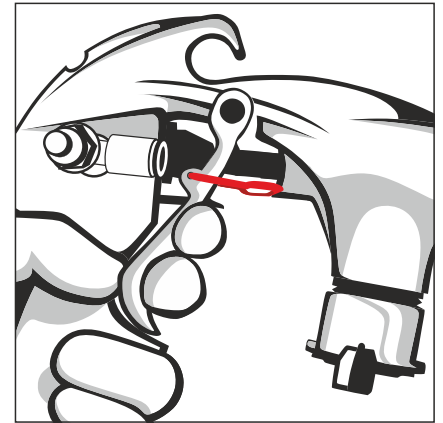

6. Block the gun's trigger.

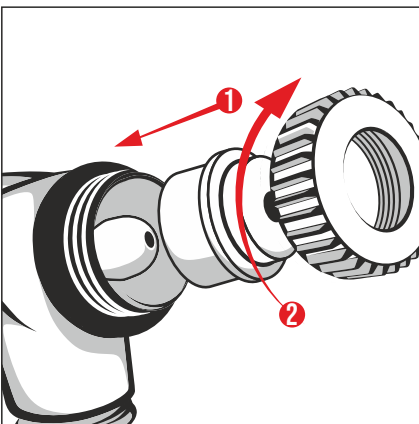

7. Place one of the nozzles on the needle of gun and screw the cap.

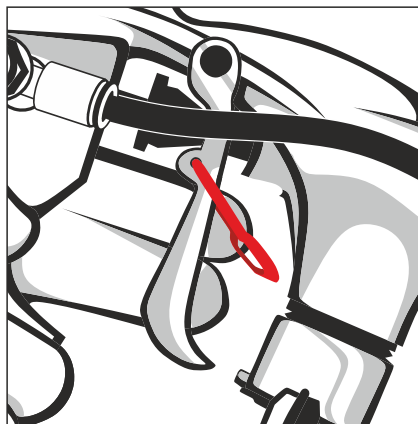

8. Unblock the trigger of the gun.

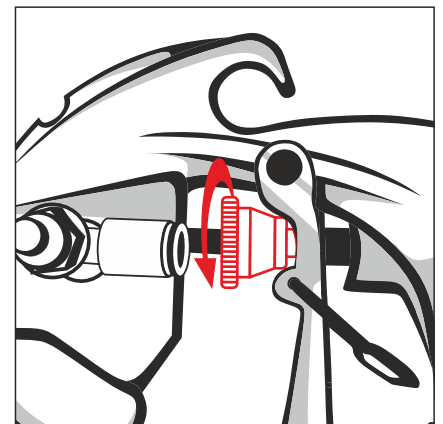

9. Screw needle to needle's cap. Ready!

OPTION 2

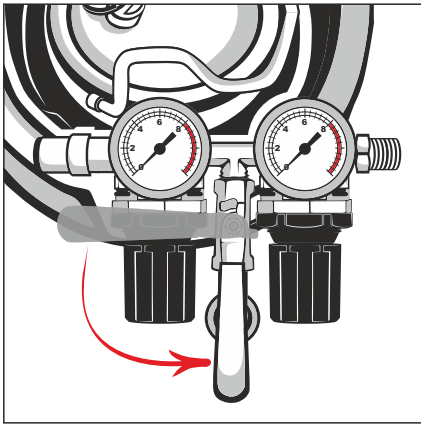

1. Screw the reductor into and open the ball valve on the reductor.

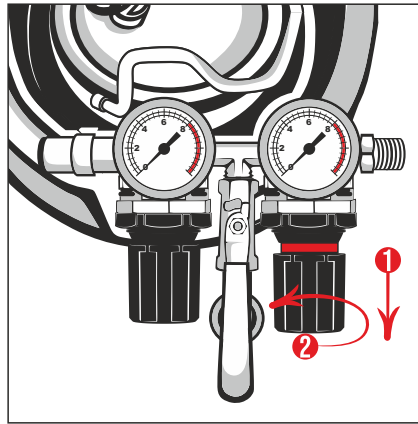

2. Using your hand pull the knob handle of the reductor and turn it left until you will feel resistance. Repeat this action with the second knob handle (manometers are often fabrically unscrewed).

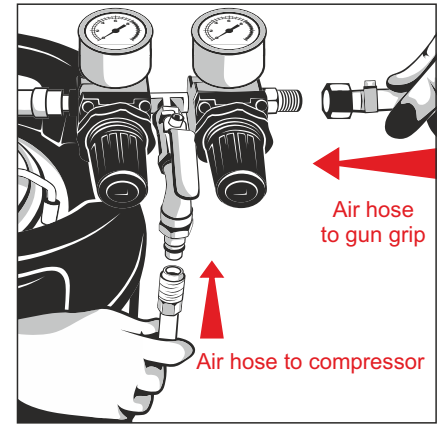

3. Connect air supply hose to compressor and air supply hose to gun grip.

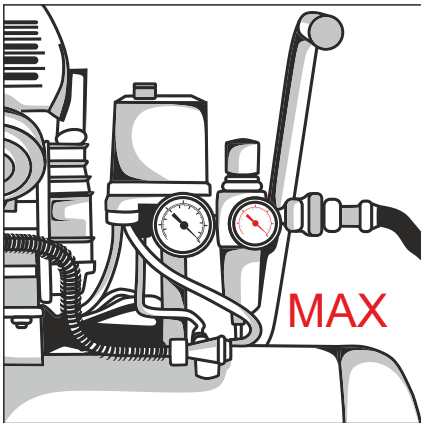

4. Set maximum pressure on the compressor. Compressor should have at least 2 pistons in V mode and capacity 50 L.

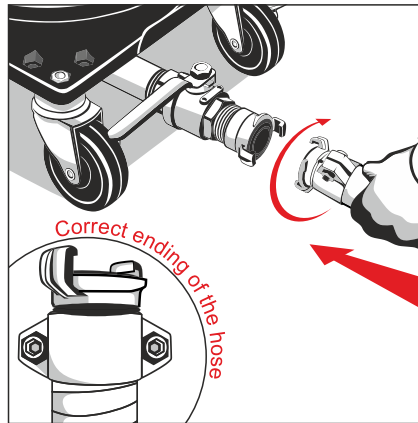

5. Attach to the bottom exhaust hose 25 mm ended with GEKA claw coupling **with a strong clamp bracket**.

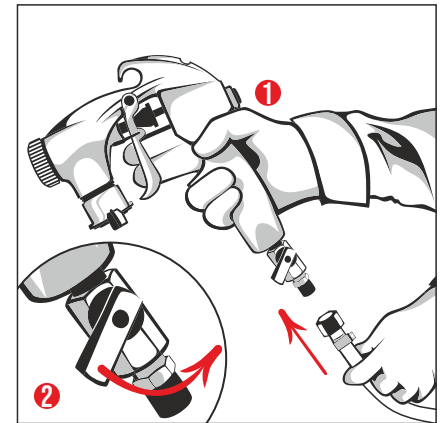

6. Connect air hose to the plaster gun. Next, open the small ball valve of the plaster gun.

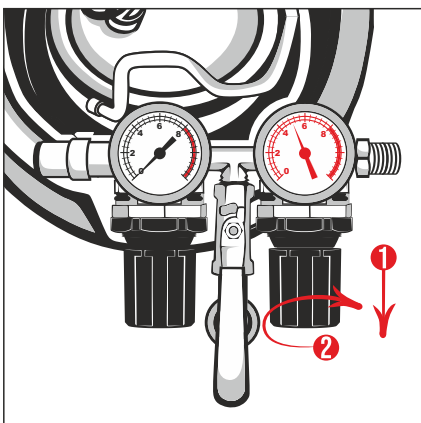

7. Turn right knob handle to the right. Set pressure for 5 BAR.

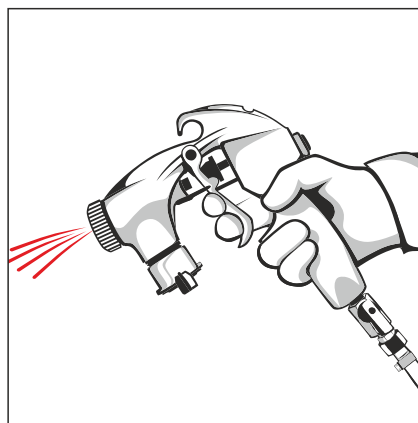

8. By pressing the trigger of the gun check if air flows correctly (pressure of air shouldn't fall below 4 BAR on right reductor of manometer). If air supply is disrupted check needle patency and check leakproofness of gun as shown in step no 9. If air supply flows correctly skip step 9.

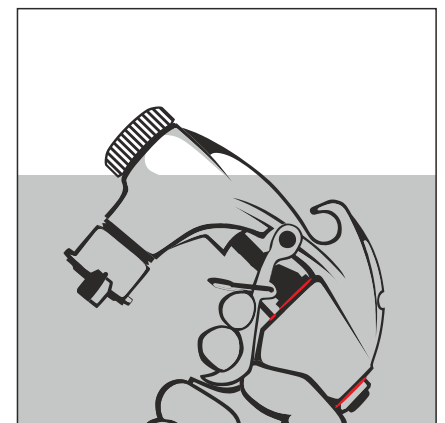

9. Check leakproofness of gun by drowning it in water so it's nozzle is above water level and pull the trigger. On the picture are marked places where leaks may probably appear. If air supply flows correctly skip this step.

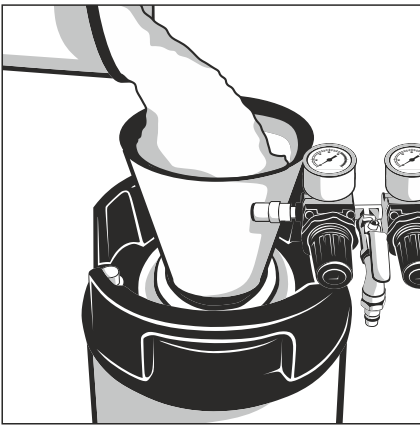

10. Open the tank. Pour material with proper consistency (liquid) to the tank and close it.

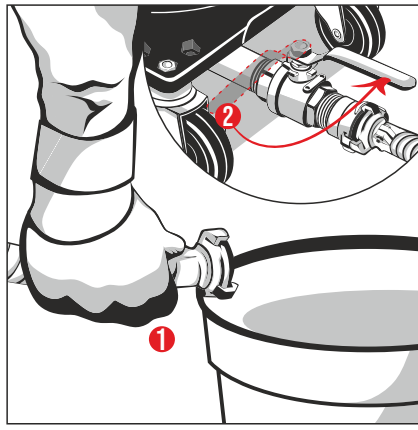

11. Put material hose above bucket or different container and open ball valve near the bottom exhaust of the tank.

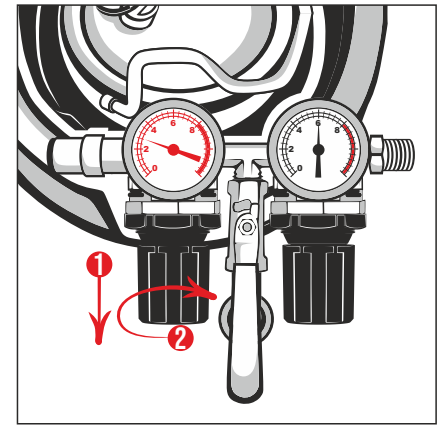

12. Increase the pressure in tank until material flows freely. Material should have runny consistency. Remember that pressure at the end of hose has to be for sure less than pressure of air that flows from needle.



13. Material should flow freely through the hose. If material blocks in the hose it should be diluted.

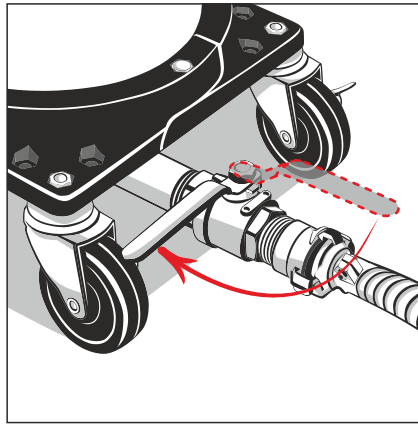

14. Close the material valve.

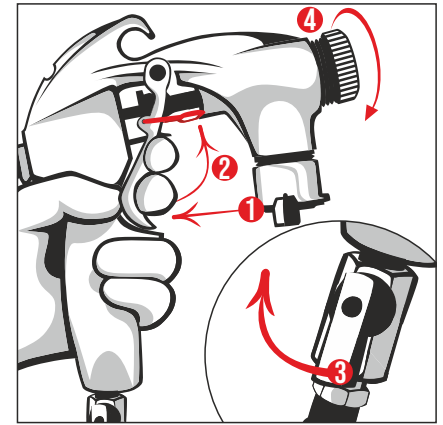

15. Press and block the trigger. Screw small ball valve on the gun then unscrew nozzle nut and remove nozzle from the gun.

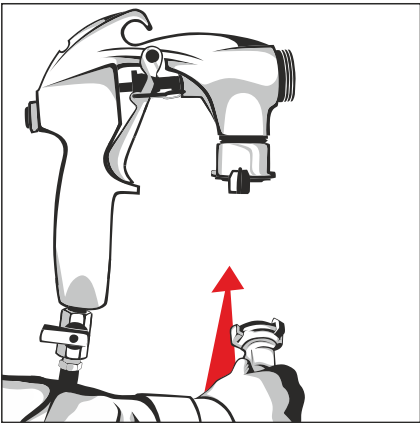

16. Attach material hose to the gun.

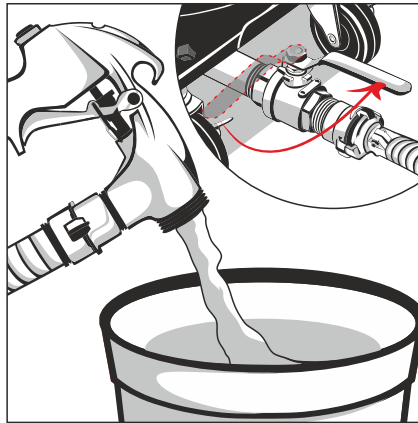

17. Open ball valve near bottom exhaust for 5 seconds and close it. Material should flow through the gun.

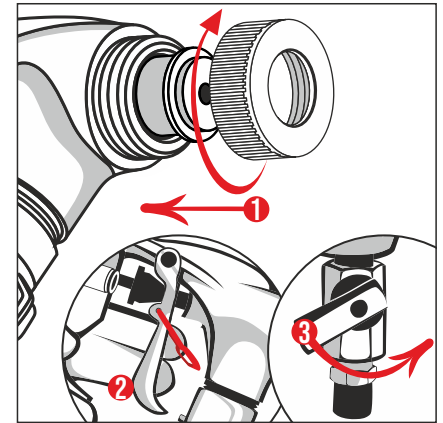

18. Put on proper nozzle to the gun and screw the nut. Release the hold of gun's trigger. **Then open small ball valve on the gun.**

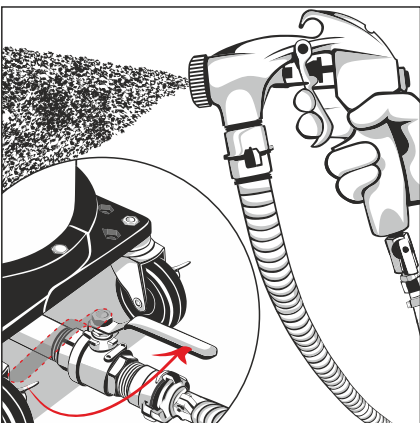

19. Open ball valve on the bottom exhaust of the tank. You can start working!

Unit while using option two is NOT meant to use for spraying dolomite or lime plaster finish.

ATTENTION If you are using hoses longer than 5 metres or you are working on heights increase the pressure on the tank so that you will balance higher resistance of material in the hose. Use material hose that has inside diameter 25 mm.

REMEMBER! Pressure of material that runs to gun's needle has to be 1-2 BAR less than pressure of air that flows through the needle.

For plaster and gypsum substances it is recommended to add about 5-15% of water.

Always first cut supply of material then supply of air!

NEVER close the small ball valve on the gun grip while working.

To make cleaning of the tank and flow of the material to bottom exhaust easier spray it's inside with WD-40 product or silicone spray. Before you start working you should rinse inside of material hose with water.